

KST Precision Motorized Linear Stages

- High load capacity
- High stiffness
- 50mm, 100mm, and 200mm travel
- 5-phase stepper motor for easy setup and compatibility with our SHOT-200 and SHOT-300 series controllers.

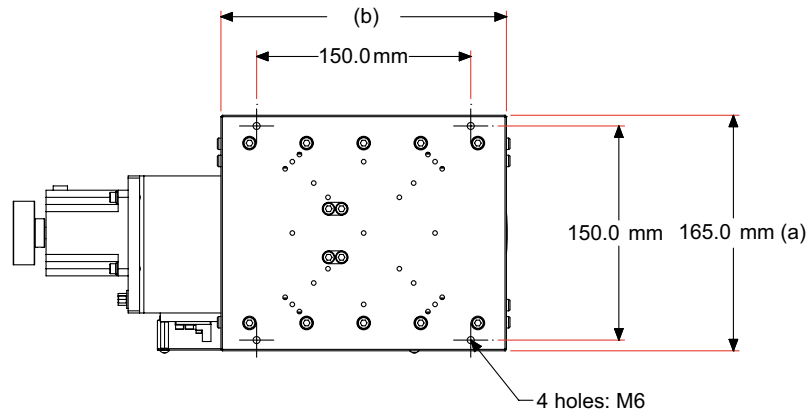

Part No. 516-0051/0101/0201



For detailed dimensions see our website
or email drawings@optosigma.com

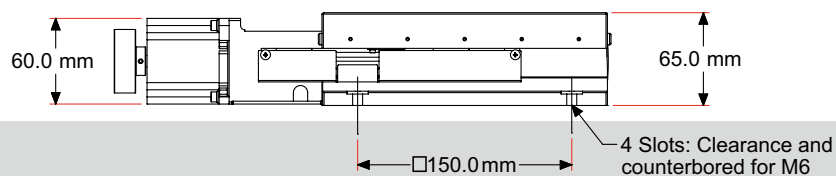

KST LINEAR SINGLE AXIS (X) STAGES

ORDERING
&
TECHNICAL SUPPORT
(949) 851-5881
FAX (949) 851-5058
E-MAIL
sales@optosigma.com
WEB
www.optosigma.com



Part No. 516-0052/0102/0202

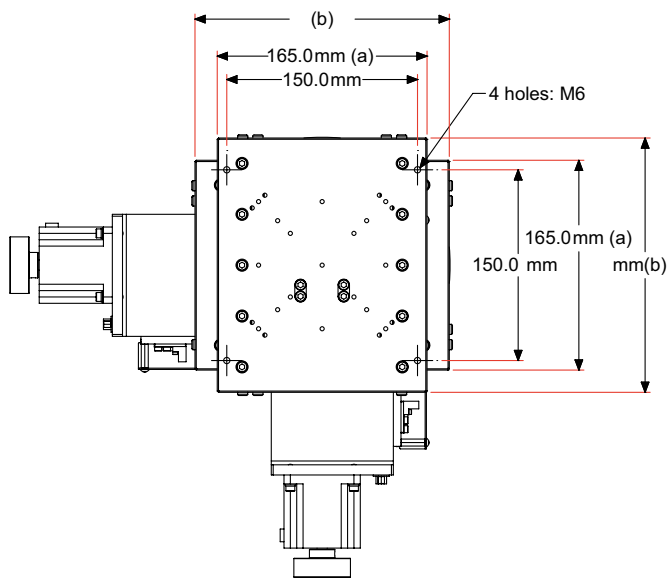

For detailed dimensions see our website
or email drawings@optosigma.com

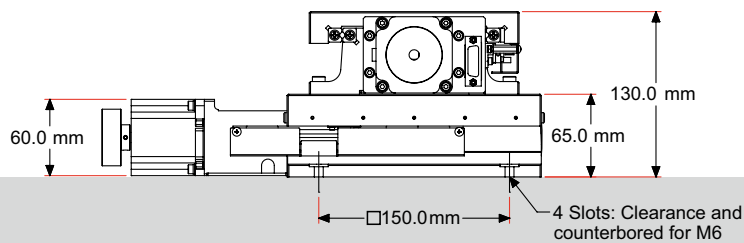

KST LINEAR DUAL AXIS (XY) STAGES



Our extensive range of products can be used to support many applications. For assistance in the selection of components or advice on a solution for your application, please contact OptoSigma by phone, fax or E-mail.

- Piezo Stages
- Linear Stages**
- Rotation Stages
- ZF Stages
- Motorized Optics Holders
- Goniometers
- GS Closed Loop Stages
- Controllers & Drivers
- Cables & Accessories
- Software

ORDERING
&
TECHNICAL SUPPORT
(949) 851-5881
FAX (949) 851-5058
E-MAIL
sales@optosigma.com
WEB
www.optosigma.com



Part No. 516-0053/0103/0203

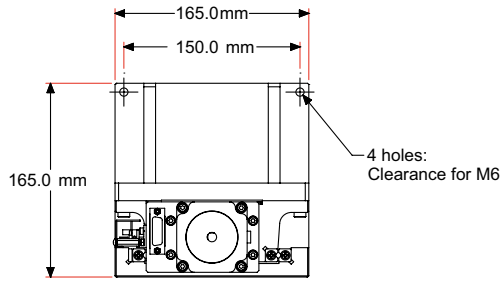

For detailed dimensions see our website or email drawings@optosigma.com

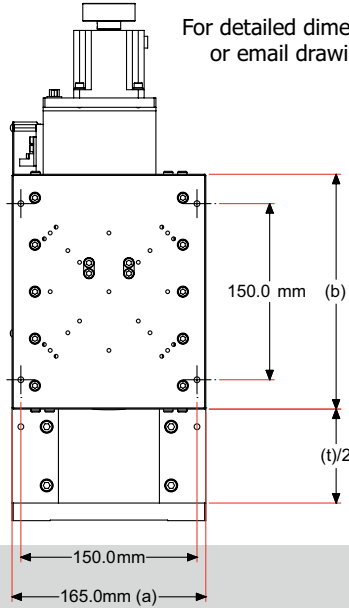

KST LINEAR SINGLE AXIS (Z) STAGES

Specifications & Tolerances

Bearing type	Crossed Roller
Repeatability	2 μm
Lost Motion	1 μm
Straightness	X,Z: 5 μm XY: 8 μm
Travel per full step	50, 100mm travel: 2 μm 200mm travel: 4 μm

KST Precision Motorized Linear Stages

Travel (t) (mm)	Table Size a x b (mm)	Load Capacity (kg)	Max. Speed (mm/sec)	Accuracy (μm)	Weight (kg)	Price	Model Number	PART NUMBER
50	165 x 165	40	10	5	10		KST-50X	516-0051
50	165 x 165	20	10	10	20		KST-50XY	516-0052
50	165 x 165	10	10	5	22		KST-50Z	516-0053
100	165 x 200	40	10	7	15		KST-100X	516-0101
100	165 x 200	20	10	12	30		KST-100XY	516-0102
100	165 x 200	10	10	7	27		KST-100Z	516-0103
200	165 x 360	40	20	8	20		KST-200X	516-0201
200	165 x 360	20	20	15	40		KST-200XY	516-0202
200	165 x 360	10	20	8	32		KST-200Z	516-0203

ORDERING & TECHNICAL SUPPORT

(949) 851-5881

FAX (949) 851-5058

E-MAIL

sales@optosigma.com

WEB

www.optosigma.com

